

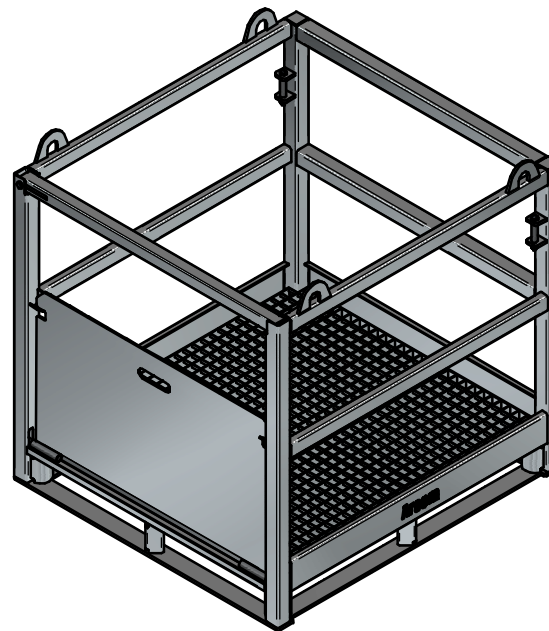

TOLERANCJE WYMIAROWE	
TOLERANCJA WYM. GABARYTOWYCH	+ -3 mm

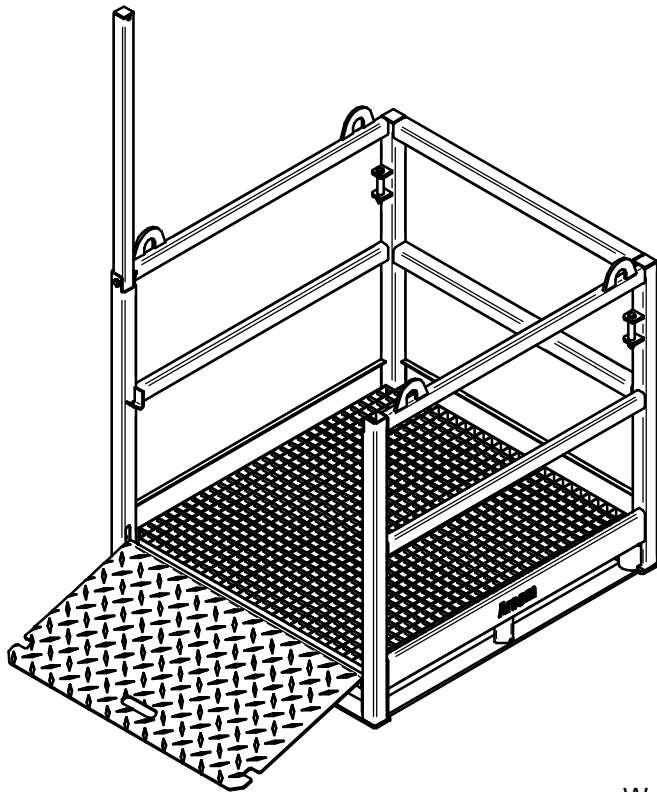
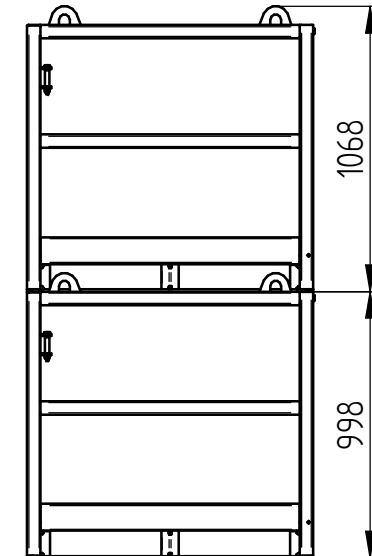
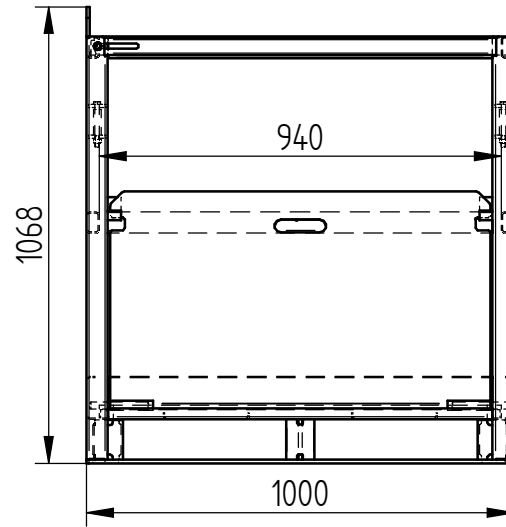
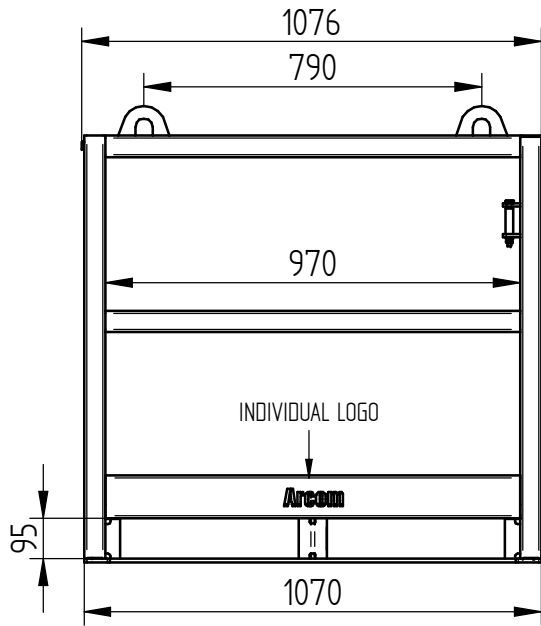

PRODUCT DATA SHEET				
DIMENSIONS	MAX LOAD	LEVELS	GAS CYLINDER CAPACITY	OPTIMAL TRANSPORT
1000 x 1076 x 1068	1600 kg	3	16 pcs.	56 pcs. / Z
B	Zmiana dotyczy długości blach giętych na bokach			26.05.2017 DTK
REWIZJA	IŁOŚĆ ZMIAN	OPIS REWIZJI		DATA ROZ.
FORMATA3	DATA:	NAZWA:	TOLERANCJE OGÓLNE	 
RYSOWAŁ:	16.12.2016	mgr inż. P.Gawlik	PN-EN-22768 m, c	
SPRAWDZIŁ:	26.05.2017		WPS: AR-135-07-FW AR-135-08-FW AR-135-09-BW	
ZATWIERDZIŁ:	NAZWA:		MASA: [kg]	NR. RYSUNKU:
SKALA:	ARG17		124 kg	ARG17-1
1:10			ARKUSZ:	1 / 42